

# Yale *ERGO* 360



# INNOVATIVE ENGINEERING DESIGNED FOR YOU

To create the best ratchet lever hoist on the market, Columbus McKinnon started with a fundamental question – how do people use ratchet lever tools to perform their jobs?

To answer that question, a global team of Columbus McKinnon engineers and application specialists worked with the Institute for Product Innovation at the University of Wuppertal, Germany, to perform an in-depth ergonomic study. Research included more than 200 voice-of-customer interviews across 10 countries, as well as numerous on-site evaluations of real-life applications for traditional lever tools.

The study revealed that lever hoists are more often used for pulling and securing than they are for lifting. And, in many applications, proper, safe and ergonomic use is not possible.

Using the data collected, Columbus McKinnon engineered and built a first-in-class product that exceeds the ergonomic and performance expectations of our customers around the world.

The result is not simply the best, but rather one of the most innovative and safest ratchet lever hoists in the world – the Yale*ERGO 360* featuring our patent-pending crank handle.

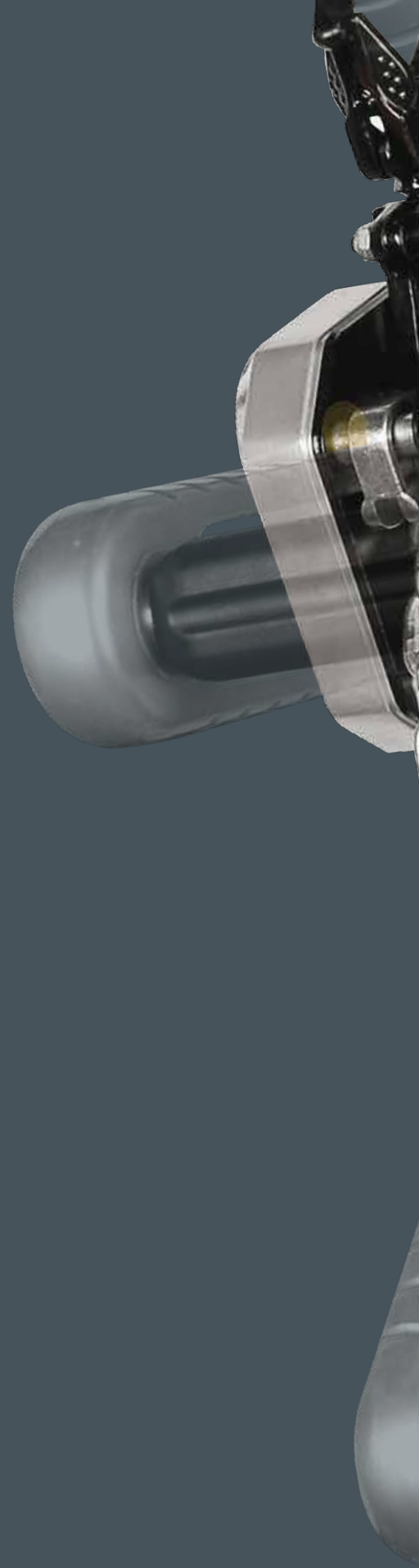



PATENT PENDING  
**CRANK HANDLE**  
DESIGNED FOR OPTIMAL  
EFFICIENCY & SAFETY

**360°** ↻

# Yale **ERGO 360**

Redefining lever-operated hoists, the Yale **ERGO 360** features the revolutionary crank handle that allows for efficient operation in both lifting and pulling applications.

Ergonomically designed for increased safety, the patent-pending Yale **ERGO 360** lets the operator to work up to 12 times faster and with as much as 30% less pull force than with conventional ratchet lever tools.

## **750 - 6000 KG CAPACITIES**

3000 and 6000 kg capacities available 2<sup>nd</sup> quarter

---

### **BENEFITS & FEATURES**

#### **CRANK HANDLE**

This first-of-its-kind lever handle design will revolutionize the ratchet lever hoist industry. Its unique foldable lever handle and 360° rotating action increases productivity while reducing the risk of operator injury.

#### **CONVENIENT DIRECTIONAL INDICATOR**

Easy-to-use, highly visible directional indicator located on the handle clearly shows the operating direction as lifting, lowering or neutral.

#### **EASY & SMOOTH FREE CHAINING**

For quick take up and positioning of slack chain – even with one hand. Designed not to accidentally free chain while under load. Cast chain end stop allows the user to easily position the chain in free-chaining mode and prevents it from entering the liftwheel and jamming the hoist.

#### **POSITIVE LOAD CONTROL**

Enclosed Weston-type brake stays clean and dry for precise load positioning.

#### **BUILT TO LAST**

Lightweight aluminum housing withstands rigorous use and features high-quality, long-lasting bearings. Powder coat finish provides extra protection in harsh environments.

#### **EXCELLENT CORROSION PROTECTION**

Robust chain guide and chain stripper made from cast steel and zinc-plated for corrosion protection.

#### **EASY-TO-INSPECT SWIVEL HOOKS**

Bolt on hooks with nylon locks simplify the inspection (process). Hooks are forged, allowing them to yield under overload without breaking. Cast safety latches provide positive and secure load engagement.

#### **EASY IDENTIFICATION**

Each unit has a unique serial number for easy and accurate identification.

---

### **OPTIONS**

#### **INTERNAL LOAD LIMITER**

Allows handle to rotate freely when hoist is overloaded, preventing damage to the unit. Load limiter units feature a black hand wheel for quick and easy on-site identification.

#### **RADIO FREQUENCY IDENTIFICATION**

Simplify inventory and inspection management processes.

#### **SHIPYARD HOOKS**

Available for 1500 kg unit.





# THE REVOLUTIONARY CRANK HANDLE

## PATENT-PENDING DESIGN

- 360° rotation increases efficiency, allowing operators to work up to 12 times faster than with a conventional ratchet lever hoist.
- Requires 30% less pull force to operate.
- Easy and effective operation from any angle with handle that folds down and locks into position on either side of the lever.
- Design keeps the operator's body aligned with the load chain, reducing the risk of the twist effect – when a hoist twists around the chain. No need to use a second hand to stabilize the hoist.
- Operator can securely grip the grooved, no-slip handle.
- Crank handle made of durable poliamide with a heavy-duty steel core for rugged use.

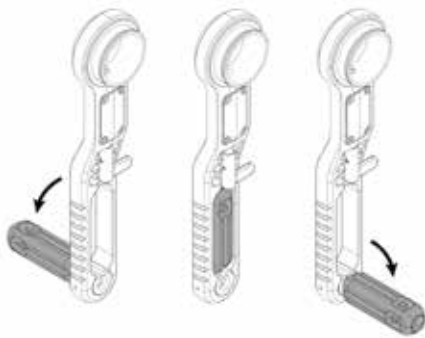
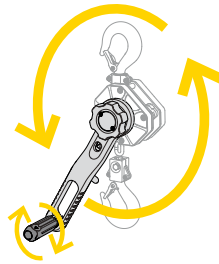

**DISTINCTIVE  
((( CLICKING SOUND )))  
ENSURES THE HANDLE  
IS LOCKED INTO POSITION**

To return handle to upright position,  
simply pull the handle outward  
and snap into place inside the lever.



## EASILY CHANGE YOUR GRIP TO SUIT THE APPLICATION

The Yale *ERGO 360* gives operators ultimate flexibility. When an application requires a customary ratcheting hand grip, the Yale *ERGO 360* can be operated like a traditional lever tool when the lever handle is in the upright position.





## ERGONOMIC DESIGN DELIVERS OPTIMAL OPERATOR SAFETY



Hoist design allows the operator to work in a **safe and ergonomic** position.



Patent-pending crank handle enables smooth 360° operation, **reducing repetitive wrist action** experienced with traditional ratchet lever hoists.



Double reduction gearing and high-quality bearings **decrease required pull force by up to 30%**, reducing operator fatigue.

# EASY-TO-USE DIRECTIONAL CONTROL & FREE CHAINING

## CONVENIENT DIRECTIONAL INDICATOR

Easy-to-use, highly visible directional indicator window located in the handle clearly shows the operating direction as lifting (▲), lowering (▼) or neutral (N).

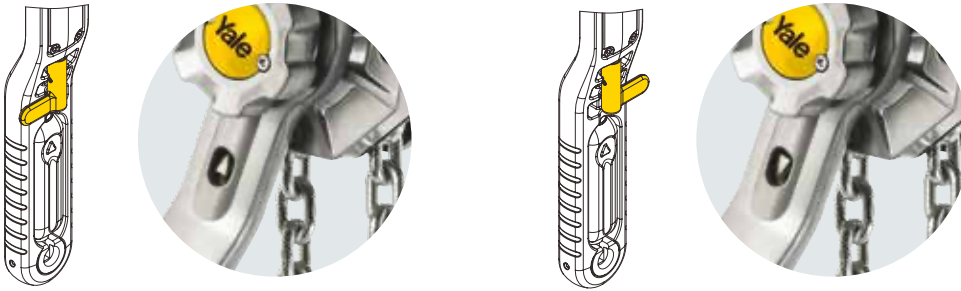

## EASY & SMOOTH FREE CHAINING

Allows for quick take up and positioning of slack chain – even with one-handed use. Designed not to accidentally free chain while under load. Cast chain end stop allows the user to quickly position the chain in free-chaining mode and prevents it from entering the liftwheel and jamming the hoist.

In this mode of operation, the chain can be pulled through the hoist in either direction by hand for quick attachment to the load. To engage the free chaining feature, remove the load and move the directional lever to the neutral (N) position.

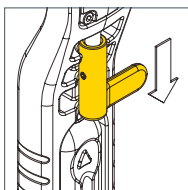

## SAFE & SECURE SELECTOR LEVER LOCKS IN PLACE TO PREVENT ACCIDENTALLY SWITCHING.

Pull down on the selector lever to unlock it, turn it to the desired direction, and release it into the locking position.

## EASILY CARRY & TRANSPORT WITH JUST ONE HAND

When folded out, the lever handle can serve as a carrying grip for easy transport. Simply attach the end stop to the hook and slip the hook onto the crank handle to lift and carry the unit with one hand.



## Technical data model YaleERGO 360

Model	EAN-No. 4053981**	Capacity  kg	Number of chain falls	Chain dimensions d x p mm	Lift with one full lever turn mm	Handle pull at WLL  daN	Weight at standard lift (1.5 m)  kg
YaleERGO 360 750	**979625	750	1	5.6x17.1	27.2	20	6.6
YaleERGO 360 1500	**979632	1500	1	7.1x21	21.7	26	9.5
YaleERGO 360 3000 <sup>1</sup>	**979649	3000	1	10x28	20.1	40	16.8
YaleERGO 360 6000 <sup>1</sup>	**981055	6000	2	10x28	10.1	42	28.6

<sup>1</sup>available 2<sup>nd</sup> quarter

## Dimensions model YaleERGO 360

Model	YaleERGO 360 750	YaleERGO 360 1500	YaleERGO 360 3000	YaleERGO 360 6000
A min., mm	320	375	445	563
B, mm	20	26	37	45
C, mm	27	31	40	44
D, mm	18	21	28	35
E, mm	327	327	377	377
F, mm	300	300	350	350
G, mm	40	51	57	87
H, mm	81	96	123	162
J, mm	121	147	180	238
K, mm	56	69	86	86
L, mm	105	110	121	121
M, mm	161	179	207	207
N, mm	30	30	30	30
O, mm	120	120	120	120
P, mm	257	273	299	299

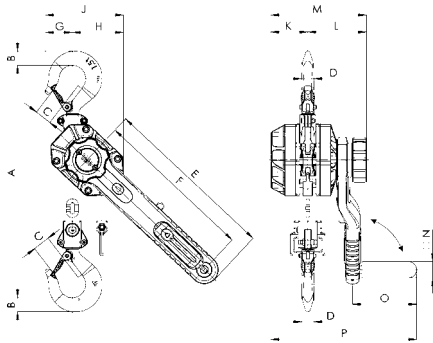

Model YaleERGO 360, 750 - 3000 kg,  
single fall

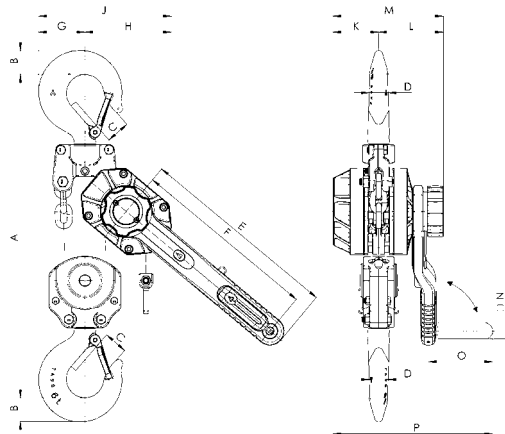

Model YaleERGO 360, 6000 kg,  
double fall



## EASIER MAINTENANCE & INSPECTION

For quicker maintenance and lower repair costs, screws are set into the hoist body to protect them from potential damage.

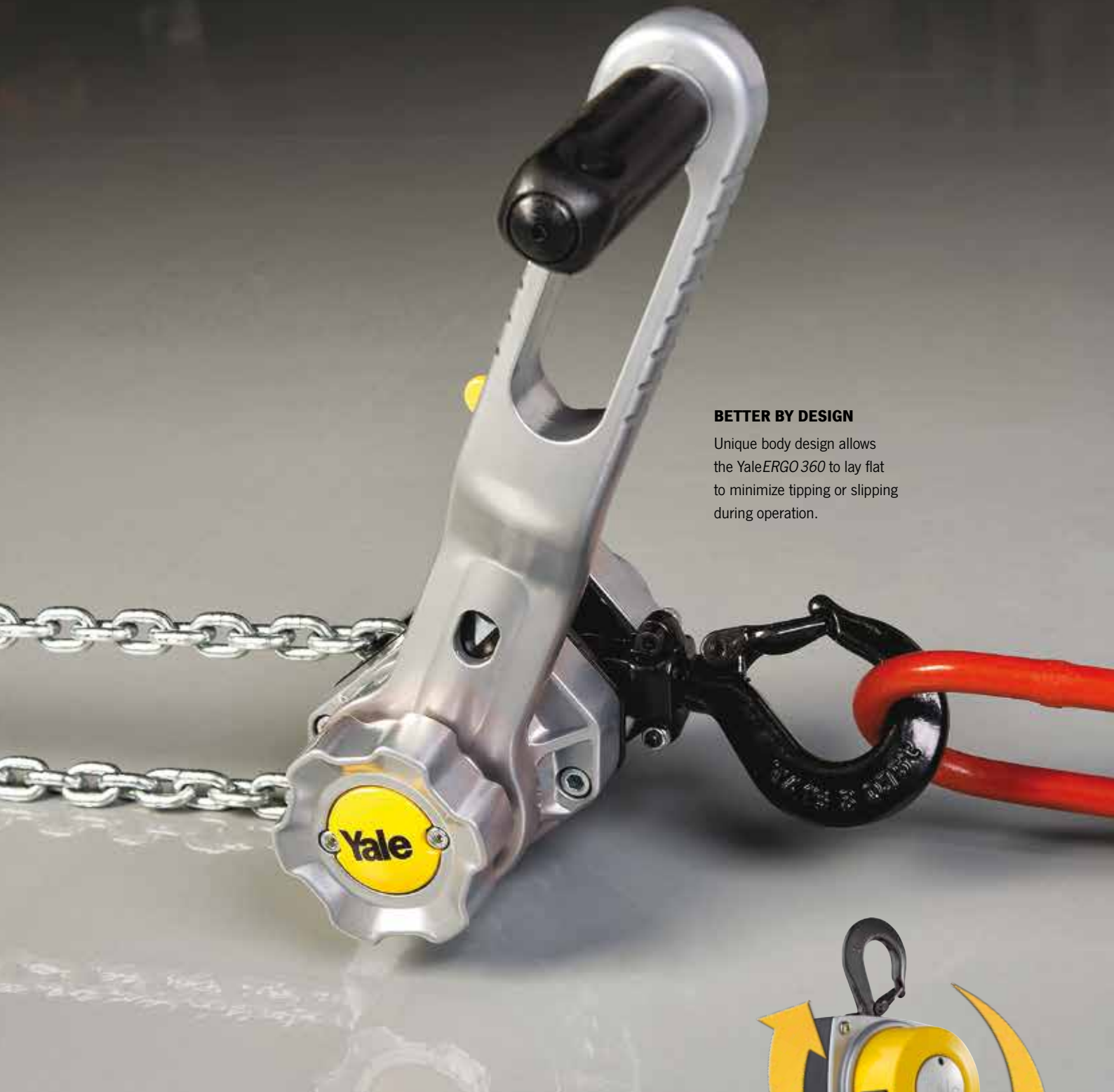

#### **BETTER BY DESIGN**

Unique body design allows the Yale *ERGO 360* to lay flat to minimize tipping or slipping during operation.

## **EXPERIENCE THE 360° ADVANTAGE**

The Yale *ERGO 360* joins the Columbus McKinnon family of hoist products that harness the versatility and safety of 360° engineering and design. The Yale *ERGO*'s companion product – the Yale *lift 360* – is a one-of-a-kind manual chain hoist. Its patented hand chain cover rotates a full 360° to allow for pulling and lifting of loads from virtually any angle, helping to minimize side-pulling.

With capacities from 500 up to 20000 kg and ultimate flexibility, the Yale *lift 360* hand chain hoist is ideal for a wide range of applications.

